

SUPPLYING POWER ON THE 1-WIRE NET

1-Wire chips get both their power and network connection over the same line, making the connections extremely economical. When adding power-consuming devices to the 1-Wire node, the same line can also supply power to them using one or more of the techniques described herein. Typical examples could be as simple as driving an LED or operating a solenoid, or as complex as powering a pressure sensor. In such cases, the most convenient method would be to transfer their energy requirements over the same 1-Wire communication line. This note will review some methods for providing power on the net including a technique for accumulating low level energy and releasing it as a high energy burst on demand.

In general, solutions to the problem of supplying power on the 1-Wire line fall into one of the following four methods. Keep in mind that regardless of which method is chosen, consideration must also be given to the energy required, its duration and its distance from the bus master.

- Sourcing power whenever the line is above 3.5V.
- Sourcing power whenever the line is high by transferring charge to a capacitor through a blocking diode.
- Sourcing power with a strong pull-up during idle communication time.
- Alternative power source using additional wires and connections.

TAP THE POWER AVAILABLE BETWEEN 3.5 AND 5V

Because 1-Wire devices can operate with a 3V supply, the energy available between the bus supply levels of 3.5 and 5 volts can be tapped. This is equivalent to operating the load in shunt mode and can be used to operate clamp type loads such as LEDs. This requires that the total voltage drop across the LED(s) be at least 3.5V. While it is possible to connect the shunt load permanently across the bus, where needed the load can be operated under bus master control by connecting it between the 1-Wire DATA lead and the output of an addressable switch as shown in **Figure 1**. In this mode, 1-Wire communication takes place below 3.5V and power delivery occurs above that value. Whenever the output of the DS2406 is pulled low the LED is on and the voltage on the bus is approximately equal to 3.5V, the forward voltage of the LED. When the output is turned off, the LED is off and the bus voltage is at its nominal 5V value. Operational current is supplied by the bus master which for the DS2480 based DS9097U COM port adapter is typically limited to about 5 milliamps, but can be increased to about 15 milliamps with the strong pull-up under software control. Other circuits could be designed to supply more power than the DS2480.

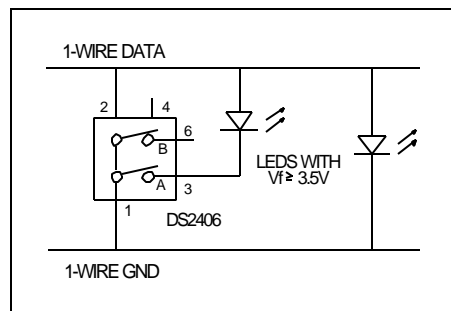

Figure 1 Using the power available between 3.5 and 5V directly and under bus master control.

TRANSFERRING CHARGE TO A CAPACITOR THROUGH A BLOCKING DIODE

For some applications it may be acceptable to use a series Schottky diode and capacitor across the 1-Wire bus to generate a local supply on the net at the point of interest. Refer to **Figure 2**. An example for this technique would be the DS2423 counter used as a wind speed sensor in the 1-Wire weather station which uses a BAT54S for the Schottky diode and a .01 μ F ceramic capacitor for C1. During idle communication periods when the bus is at 5V, the circuit 'steals' power from the line to charge the capacitor and power the load. This is a discrete implementation of the parasite power technique used internally by 1-Wire devices to provide their own operating power. The value used for C1 depends on the current consumption of its load and how long the voltage must be held above a design value. While simple and economical the circuit adds both leakage and capacitive loads that reduce the range and capability of the 1-Wire net. These place an upper limit to the capacitor value used and how many can be placed on the net. Consideration must also be given to the fact that in the event the capacitor is shorted or held in a discharged state by its load, the net will also be shorted and inoperable. No further communication can take place until the capacitor is charged above 3.5 volts.

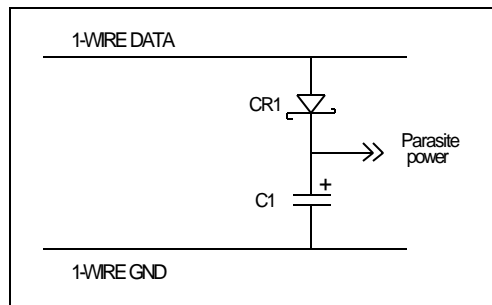

Figure 2 Using a Schottky diode and capacitor to supply local power on the 1-Wire net.

CONDITIONALLY DELIVERING ENERGY UNDER BUS MASTER CONTROL

As shown in **Figure 3**, the half wave rectifier of **Figure 2** can be isolated between two addressable switches controlled by the line master. When the input switch is closed, the capacitor receives charge over the DATA line of the 1-Wire net in the same manner as the circuit of **Figure 2**. A significant advantage of the arrangement is that when the switch is opened the capacitor and its charge is isolated from the 1-Wire net and normal communication resumes without the burden of the capacitive and leakage loads of C1. When the stored energy is needed, the output (power dump) switch is closed and the capacitor is discharged through the load. Note that while reference was made to a capacitor, a rechargeable battery could be used equally well. Important elements of the concept and architecture are the low-level transfer of energy from the bus master to a storage element, and subsequent use of that energy in a burst. This is somewhat similar in concept to the way the circuitry used in a flash camera develops the energy needed to fire the flashbulb. Equally important is the isolation of the storage element from the 1-Wire net so a failure doesn't bring down the net, and the complete control of energy source cycling by the bus master.

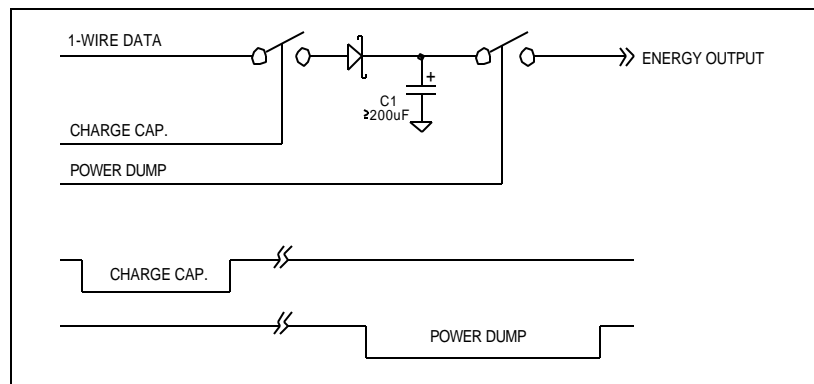

Figure 3 A parasite powered 1-Wire remote high-energy source concept.

A practical example of the concept using a DS2406 as the control element and pFETs for the switches is shown in **Figure 4**. Notice that the MICREL MIC94031 FET isolation switches specified are four terminal devices with the substrate terminal brought out. This provides for correct biasing of the terminal under all operating conditions. The gate pull-up resistor shown unlabeled is internal to the chip but shown for clarity. In order to insure that both switches can not be turned on at the same time and possibly bring down the net, a lockout circuit is constructed using U2 a 74HC126 tri-state gate. By design U2 only allows alternate enabling of the pass gates to charge and discharge the energy storage element C1. As shown in the truth table of **Figure 4**, if both outputs of the DS2406 are simultaneously placed in the same logic state, either intentionally or by accident, U2 insures that neither pass gate is turned on.

In operation, C1 is charged by commanding output B of U1 (pin 6) the DS2406 to a logic zero. This turns on Q1, connecting the 1-Wire DATA line to C1 through diode CR2 which prevents C1 from discharging back through the 1-Wire net. If the diode were not present and a 1-Wire device were to be placed on the bus when the pass gate was turned on, its Presence Pulse would short and discharge the capacitor possibly damaging the chip. In the initial state with no charge on C1, the gate of Q2 the discharge pass gate, is held at a higher potential than the source terminal by pull-up resistor R4, so Q2 is off. When the bus master turns output B of U1 off, the charge stored on C1 is isolated from both the 1-Wire net and the load and only leakage paths exist to discharge it. When the bus master commands output A of U1 (pin 3) to a logic zero, pass gate Q2 turns on and C1 discharges through the load.

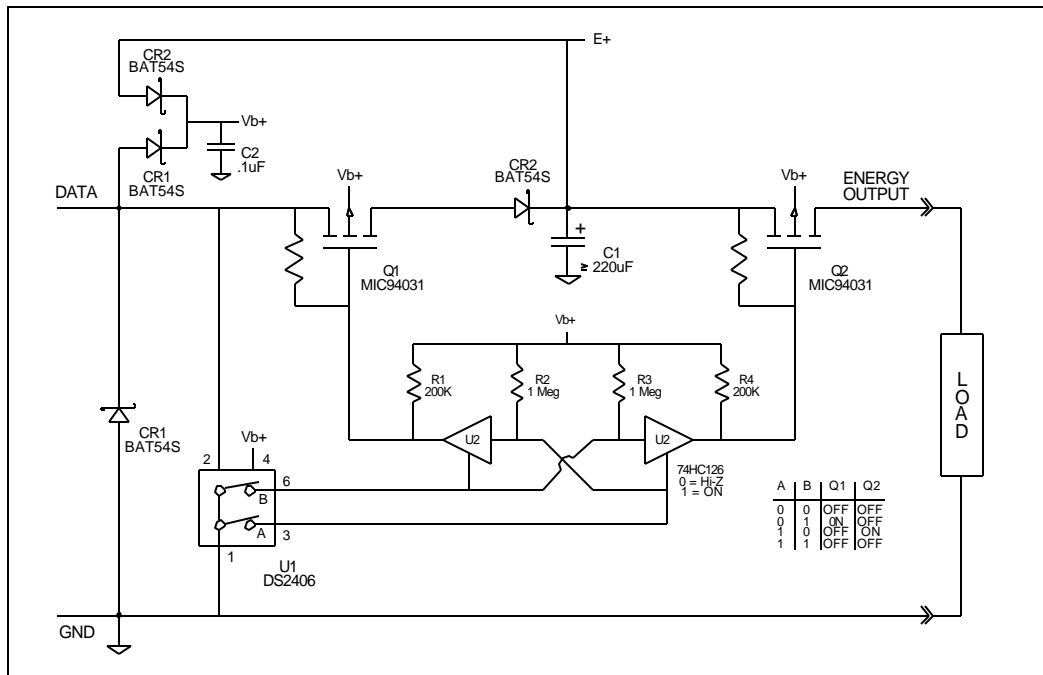

Figure 4 An isolated remote energy source based on the DS2406 addressable switch.

In a more sophisticated implementation of the concept, a barometric sensor was constructed using U1, a DS2450 Quad ADC as the 1-Wire addressable switch control element. The DS2450 also reads the charge level of the energy storage capacitor C1 and controls a sample-and-hold on the output of the sensor. A major design condition of the circuit was that the barometer required the

energy source C1 to provide up to 10mA for 22mS. A schematic of the prototype circuit is shown in **Figure 5**. In the circuit, two of the DS2450 I/O pins are used as digital outputs that control the capacitor charge and discharge via analog switch U3 and a specialized switched-capacitor voltage regulator U4 used in place of the output (discharge) analog switch. The charge pump, a MAX684 from MAXIM, provides a regulated 5V \pm 4% output as the energy capacitor discharges down to 2.7V. Surprisingly, the efficiency increases as the input voltage drops, a very useful feature when using a discharging capacitor as the energy source. The two remaining I/O pins of U1 are used as analog inputs which read the voltage on storage capacitor C1, and the voltage from the sample-and-hold (U7) that stores the output from the barometer representing the current barometric pressure. The circuit performed as expected with values up to .22 Farad for C1 the energy storage capacitor. Obviously, the more the capacitance, the longer it takes to charge and the longer the voltage level is maintained relatively constant.

In operation, pulling U1.7 low closes analog switch U3 allowing C1 to charge through CR1. CR1 prevents C1 from discharging back through the 1-Wire net. The voltage generated by charging C1 can be read as needed by U1.8 to insure that sufficient energy exists to operate the load. When U1.7 is turned off, analog switch U3 also turns off and the charge stored on C1 is completely isolated from the net. At the appropriate time, U1.6 is pulled low which enables voltage regulator U4 providing a path for C1 to discharge through barometer U5. The MPXA4115 Motorola part requires 22mS maximum to turn on and stabilize, at the end of which time the output voltage representing current atmospheric pressure is stored on C3 the sampling capacitor. After the sample, U4 turns off to minimize energy loss from the storage capacitor C1. Instead of the wide interval used in the prototype circuit to sample the barometer it would be preferable to use a narrow pulse immediately after the output has settled.

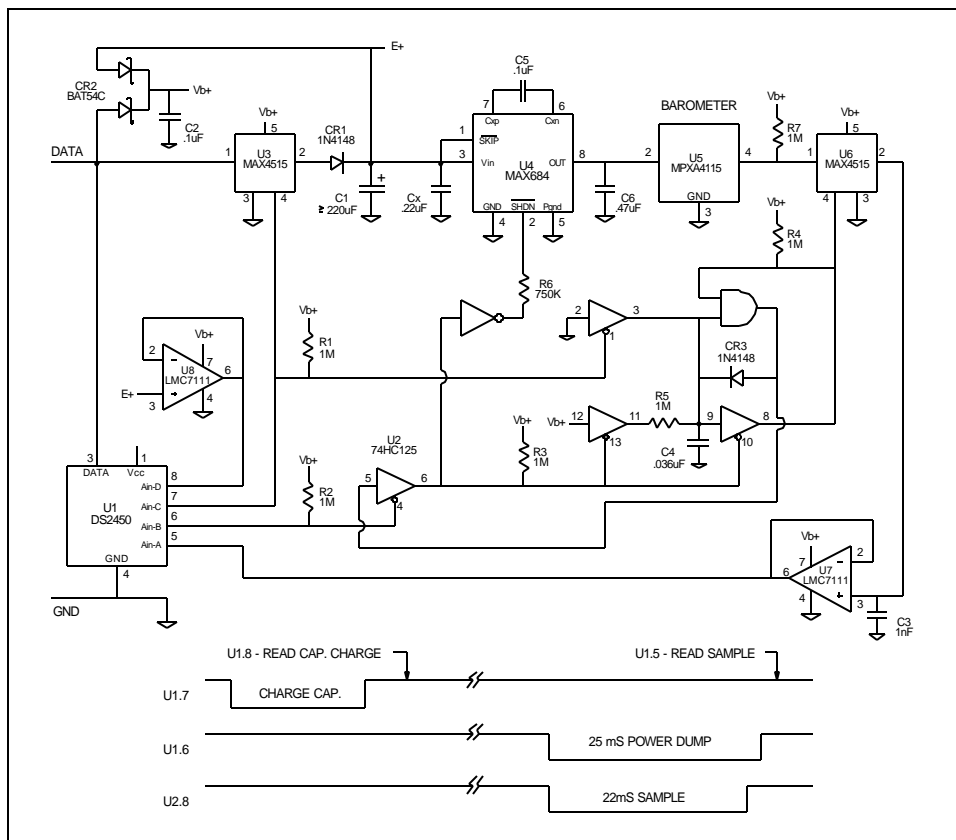

Figure 5 A 1-Wire barometer powered off the bus by an isolated and regulated energy source.

USING ADDITIONAL WIRES NORMALLY AVAILABLE IN THE CABLE

In order to obtain maximum performance, Dallas Semiconductor recommends CAT 5 unshielded twisted pair for use in connecting the 1-Wire net. However, since CAT 5 typically comes as a multiple pair cable, there is a natural inclination to use an extra pair to route power. A look at some cable properties will help in understanding how such an arrangement affects net performance. In a CAT 5 cable with multiple twisted pairs, on average any given conductor in a pair is adjacent to a second conductor in another pair for half its length. Typically, the capacitance between the two conductors of a twisted pair is approximately 50 pF/m while that between the conductors of two different pair runs about 30 pF/m. Because grounding unused conductors will increase the capacitive load seen by the line master, Dallas Semiconductor recommends that unused wires and shields be left unconnected at both ends of the cable. Still, within the constraints set by increased capacitive loading and potential cross talk caused by using the extra pairs within the cable, external power can be routed along with the 1-Wire DATA and GND communication pair. However, the loading can reduce how long the bus can be and/or the number of 1-Wire devices the net can support. In addition, current and voltage variations on the pair carrying power can induce cross talk on the 1-Wire DATA and GND that disrupts communication.

Since the bus master sees less capacitive loading when routing power over flat cable where the conductors maintain a distant and fixed separation, flat 6-conductor phone (silver satin) may be used up to about 200 feet. This assumes that 1-Wire DATA and GND have maximum separation from the power conductors by using the outer two conductors next to the 1-Wire GND to carry power. As shown in **Figure 6**, the wiring sequence should be; NC (no connection); NC; 1-Wire DATA; 1-Wire GND, then external power and ground on the two outermost conductors. This arrangement helps shield the critical DATA lead from the additional capacitive load and cross talk of the external power leads. Notice again that the two conductors prior to the 1-Wire DATA line shown in dashed lines are to be left uncommitted. As previously emphasized, if connected they will substantially increase the capacitive load seen by the DATA line. One possibility is to use 4-conductor silver satin and assemble the cable with these two slots in the RJ11 connector empty. Unfortunately, a significant disadvantage of flat cable is that it lacks the noise rejection properties of twisted pair cable, so EMI can be a significant performance problem if the net is routed near sources of electrical noise.

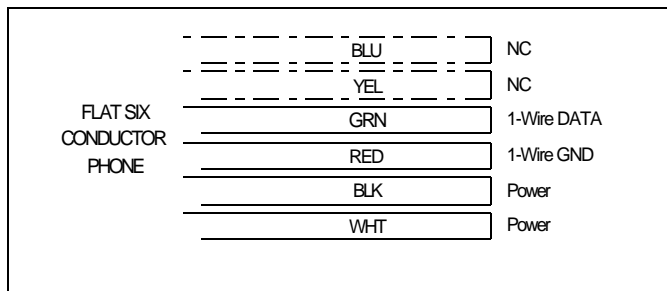

Figure 6 If power is to be routed over flat phone wire along with 1-Wire DATA and GND, use the outer two conductors by 1-Wire GND to minimize cross-talk and capacitive loading.